



# Virtualized Data Centers

## Beyond the Virtual Sum of Virtual Parts

**Presented by:**  
**KJ (Ken) Salchow, Jr.**  
**Manager, Technical Marketing**

THE WORLD RUNS BETTER WITH F5



# Evolution of the Data Center

2010	
On-demand, dynamic application & network services	10Gigabit Ethernet
Access virtualization	Broadband
Application virtualization	Fast servers
Data virtualization / functionality	Integrated apps / rich content
Network virtualization	Pervasive access
SSL, Wireless	Mobility
"Exaflood" traffic scale	Limited server virtualization

# 8 DC Virtualization Categories

- ❑ OS Virtualization
- ❑ Application Server Virtualization
- ❑ Application [Delivery] Virtualization
- ❑ Management Virtualization
- ❑ Network Virtualization
- ❑ Hardware Virtualization
- ❑ Storage Virtualization
- ❑ Service Virtualization

# Data Center Today – Limited Virtualization

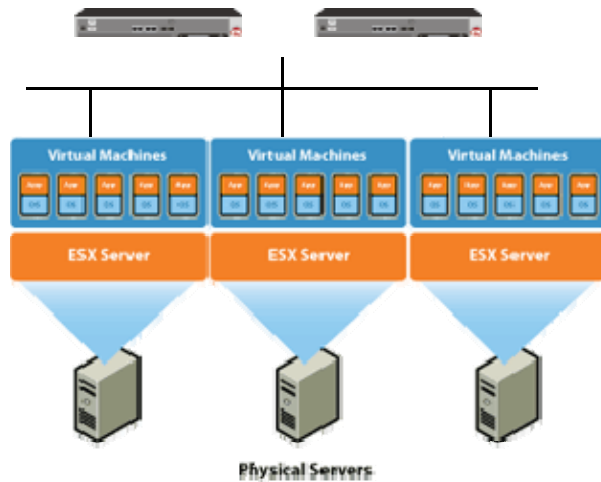

“Fewer than 10% of servers that use Intel and AMD's x86 chips—the fastest-growing part of the server market—use virtual machines, leaving lots of room for growth.”

– David Goulden, CFO, EMC, Feb. 2007

“Microsoft Senior Director Bob Visse says the company plans to give away its next-generation virtual-machine software.”

– BusinessWeek, Feb. 2007

“Greater than 17% of servers will be virtualized by 2010.”

– IDC, 2007

# The State of Virtualization

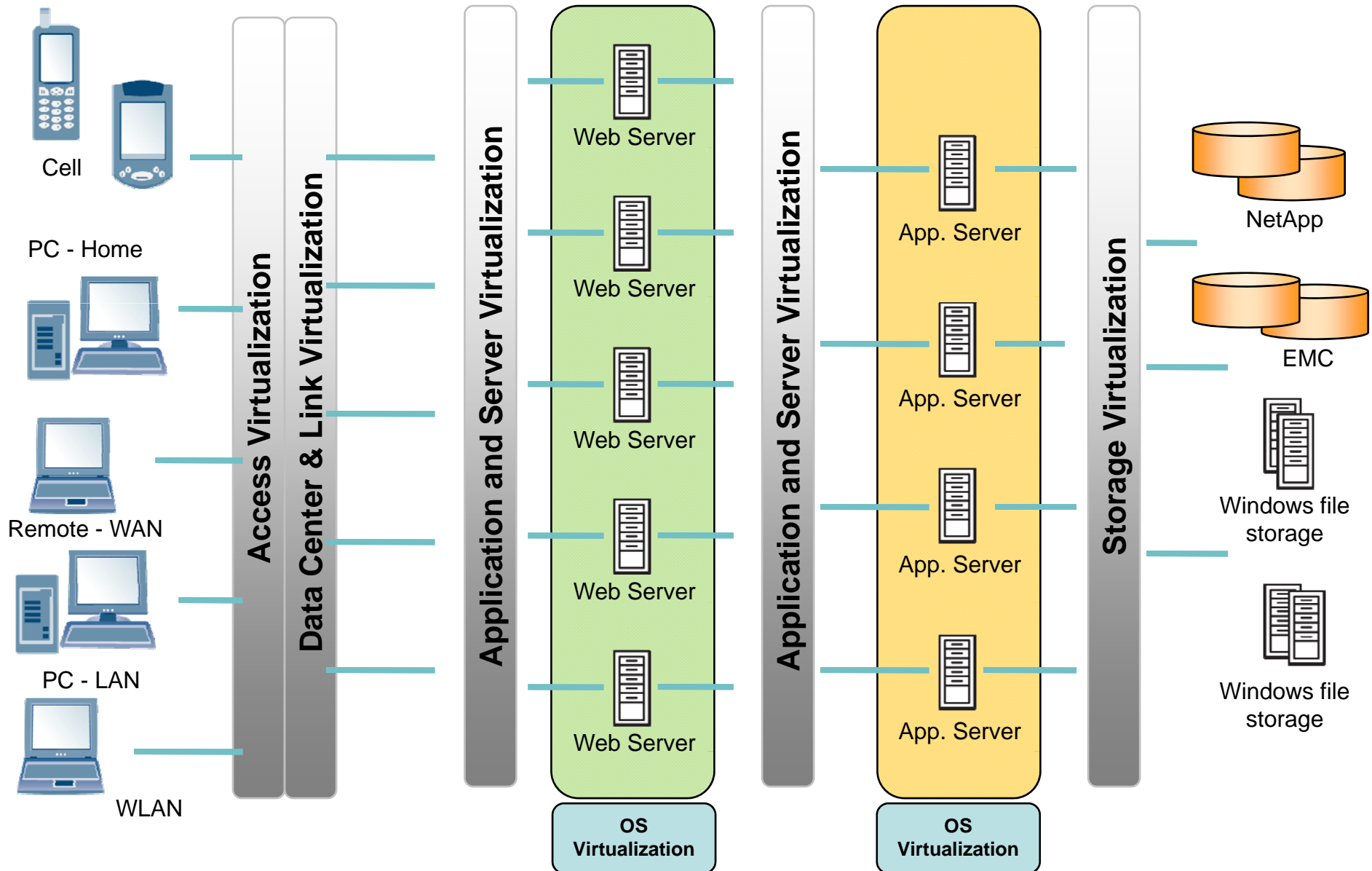

# Questioning the Value

- ❖ Multiple Virtual Servers on Consolidated Hardware?
- ❖ Green IT (less Rack Space, Power and Cooling)?
- ❖ Reduced Costs Overall?



# Where the Value REALLY is:

- ❑ Hardware Standardization
- ❑ Decreased Deployment Time
- ❑ Decreased Development and Testing Costs
- ❑ Increased Flexibility



# Dynamic Provisioning

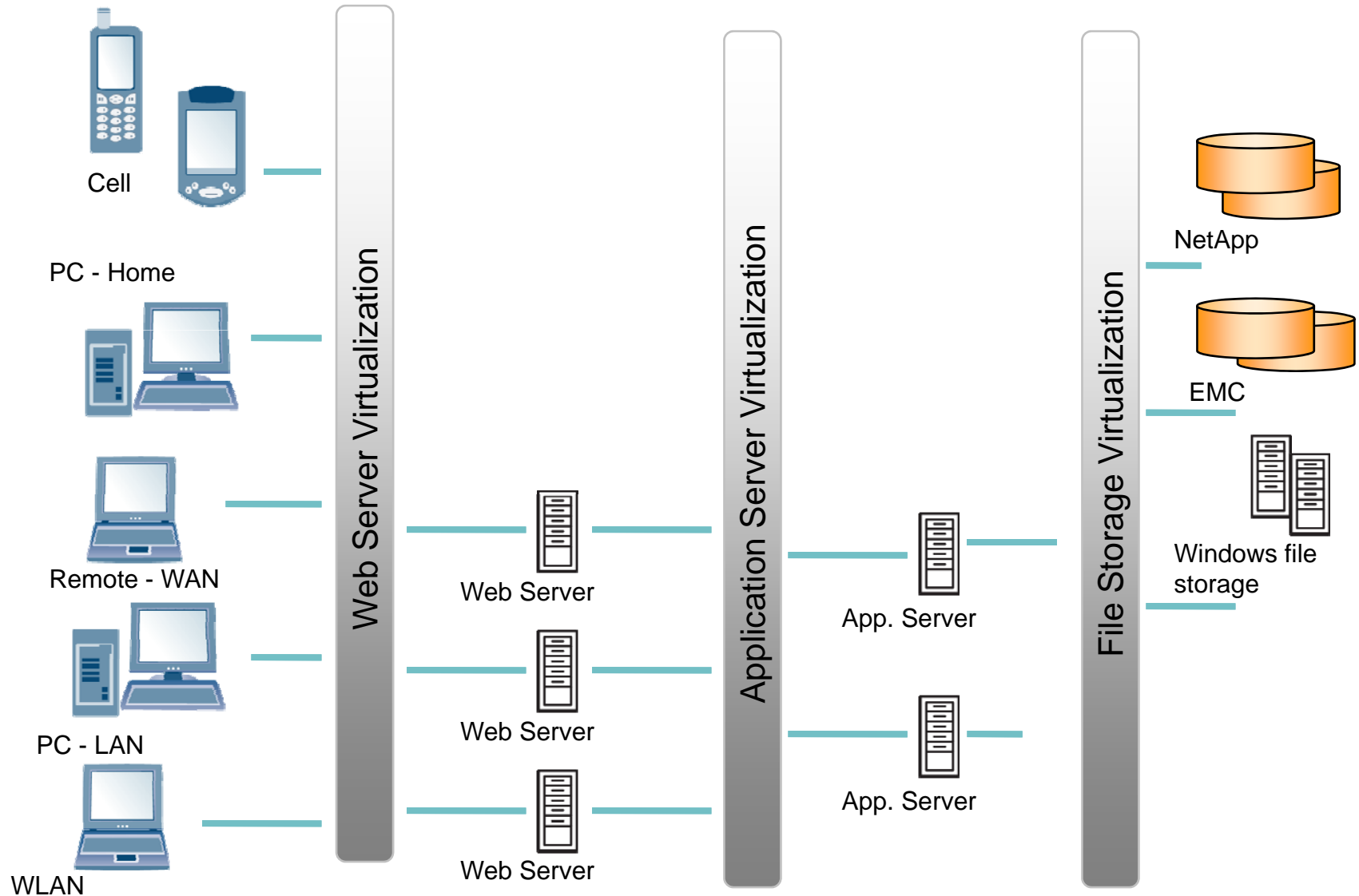

# Dynamic Provisioning in Action

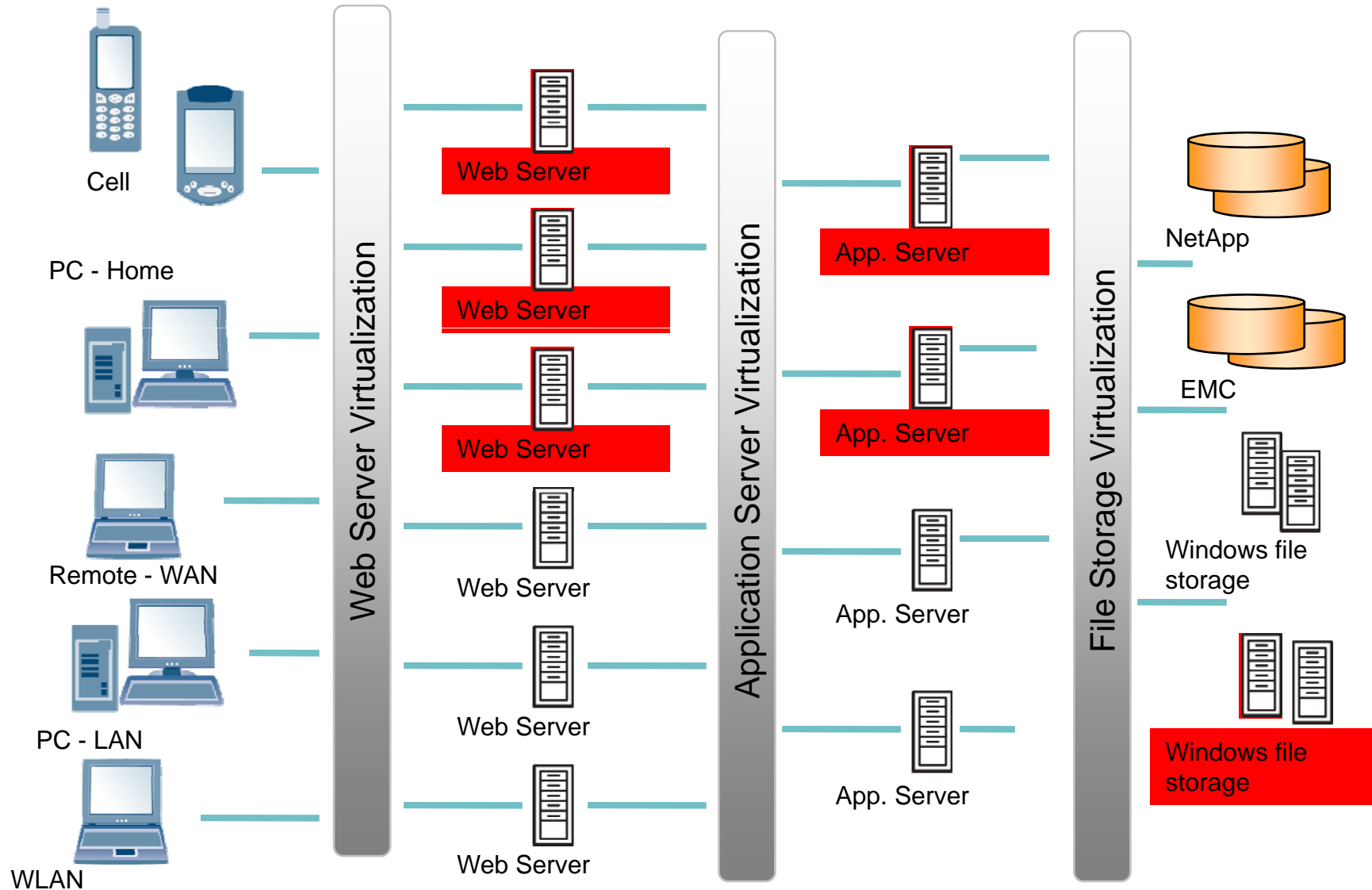

# Imagine, If You Will . .

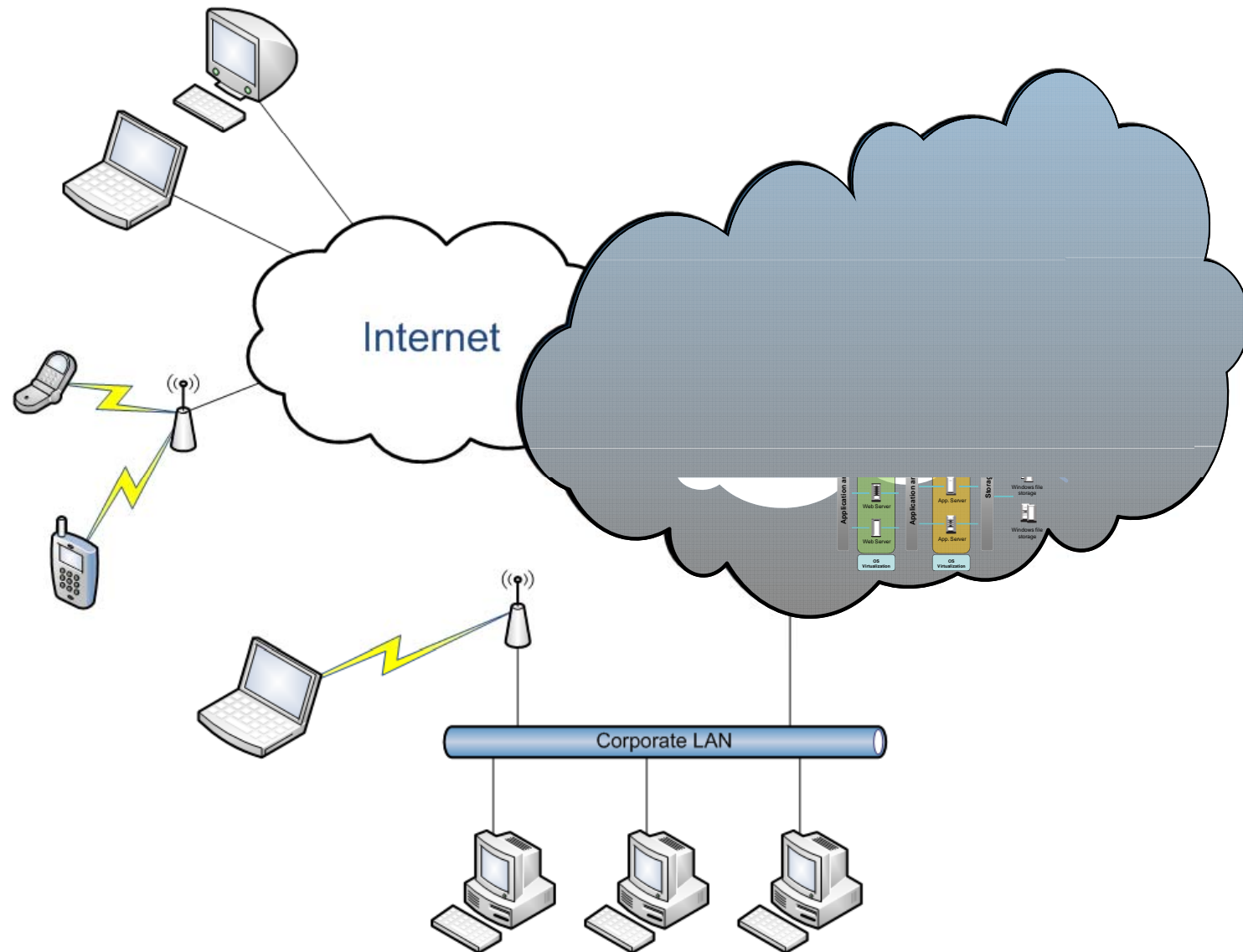

# The Sum of the Virtual Parts

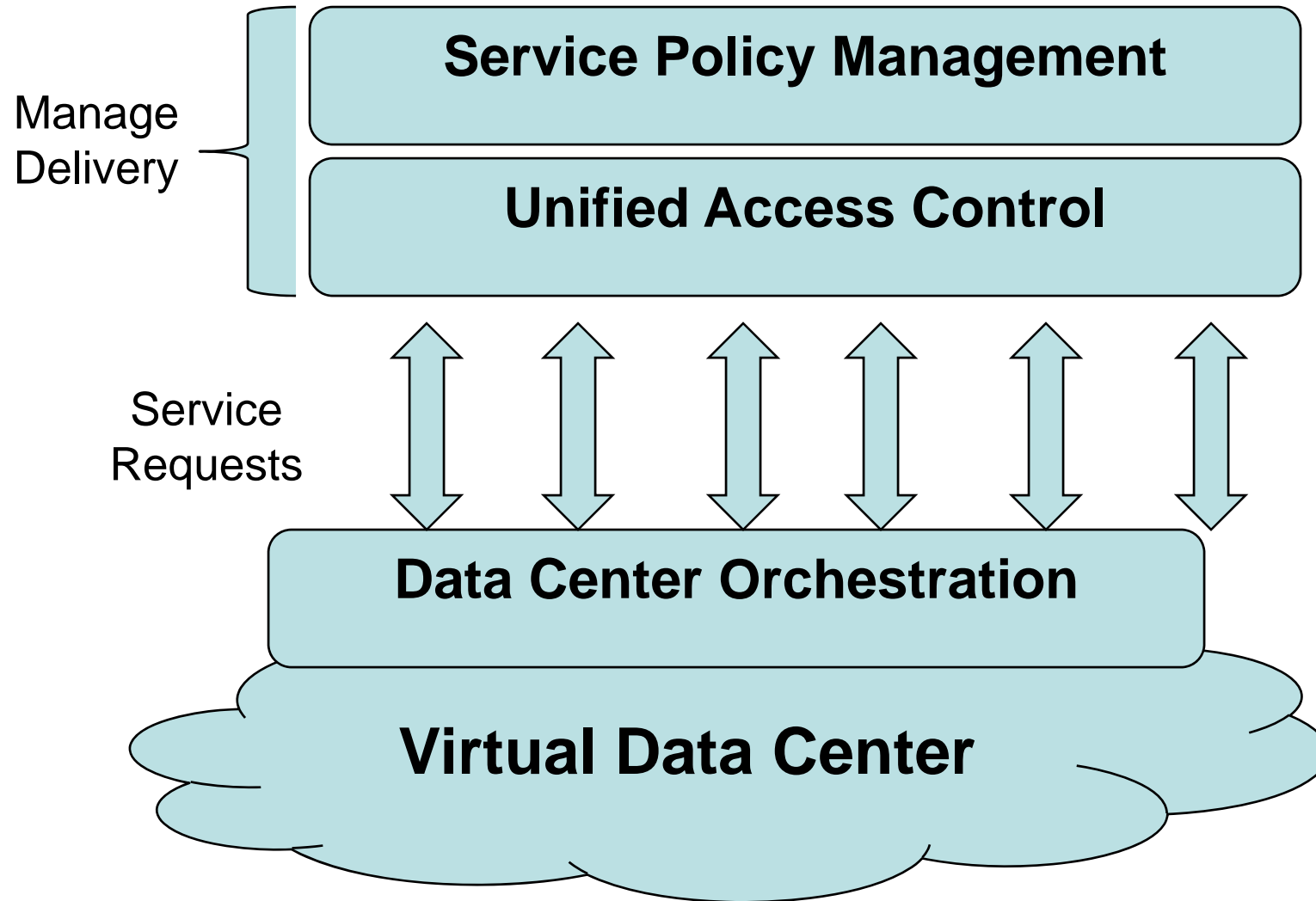

# Challenges Ahead!

- ❖ Bureaucratic IT Silos
- ❖ Single-Vendor Solutions
- ❖ No Integration
- ❖ No Management
- ❖ No Sum of the Parts Solution
- ❖ *Lack of Focus*



# The Next Steps

- ❖ Break the Barriers
- ❖ Understand the Value/Cost
- ❖ Management, Integration and Management
- ❖ Focus on the End-Game





**VIRTUAL**

THE WORLD RUNS BETTER WITH F5