

# **Network Application Optimization**

Annette Clewett

OPNET Technical Director

# What is Network Application Optimization?

- Shows how the application “behaves” in a best-case environment
- Predicts application performance in various environments
- Provides information for performance improvements and tuning
  - Network alterations
  - Client configuration
  - Server/database optimization
- Bridges the application/network gap

# NAO Service Level Management Cycle

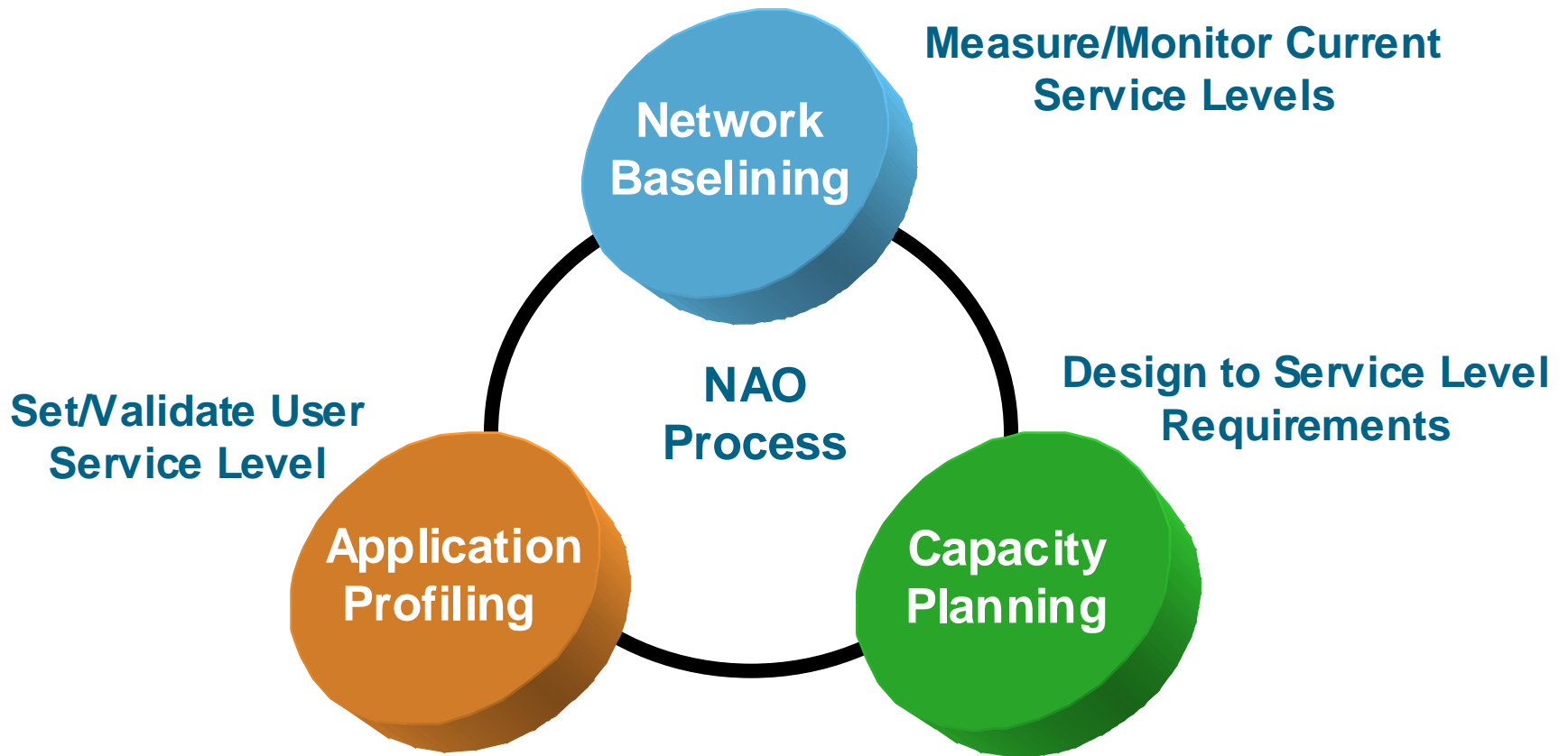

# Network Baselineing

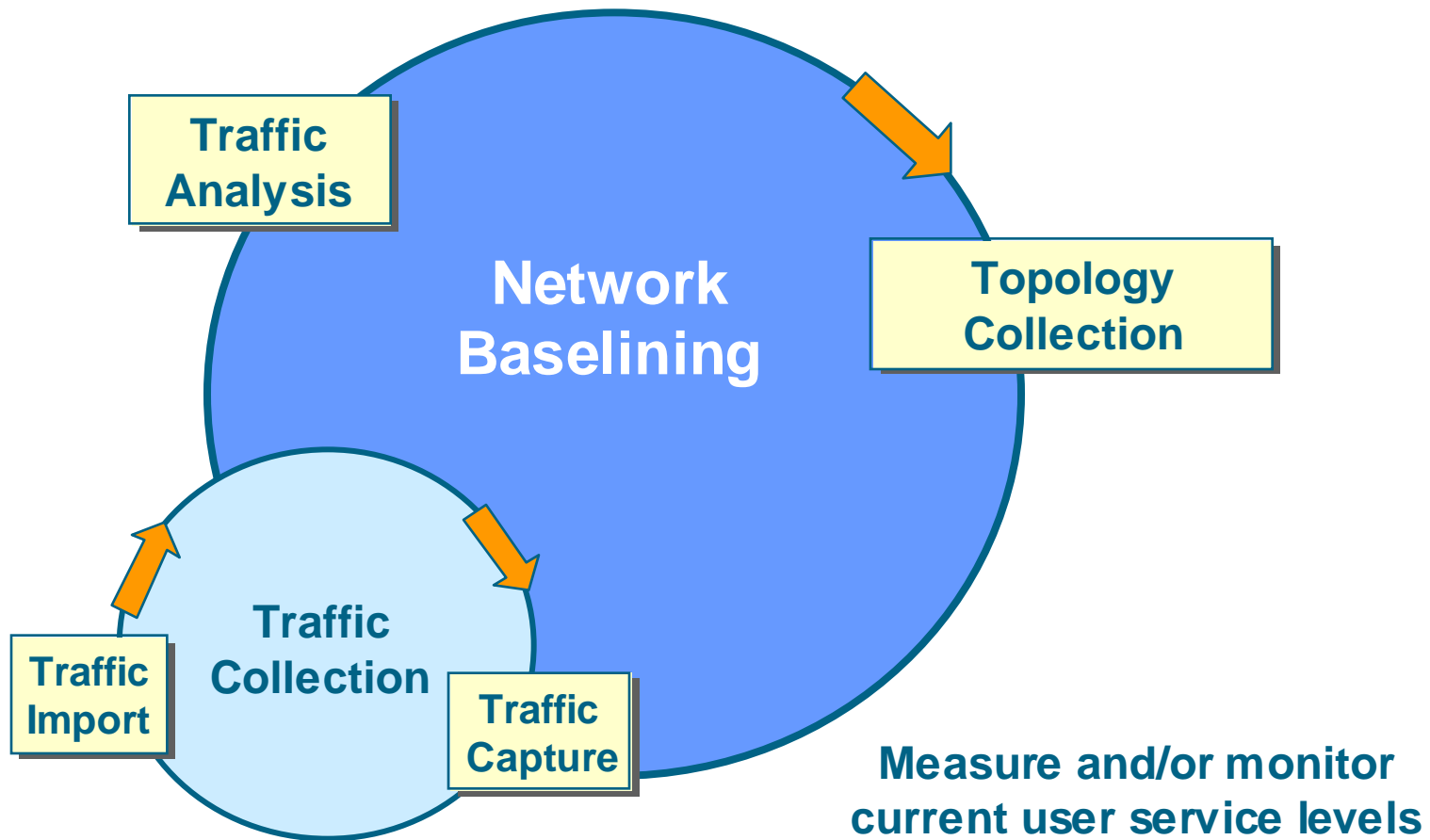

# Data to Be Collected

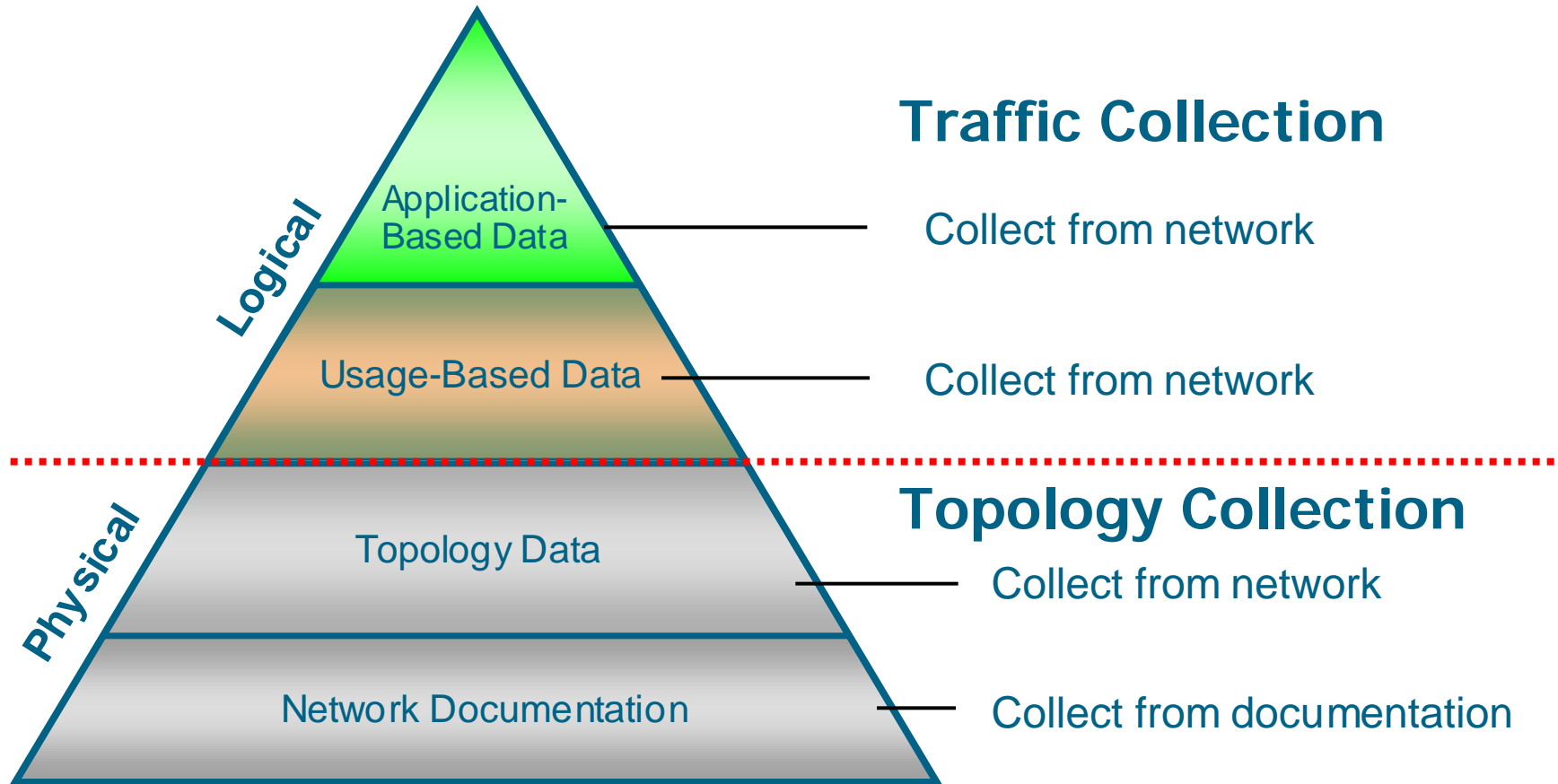

# Application Profiling

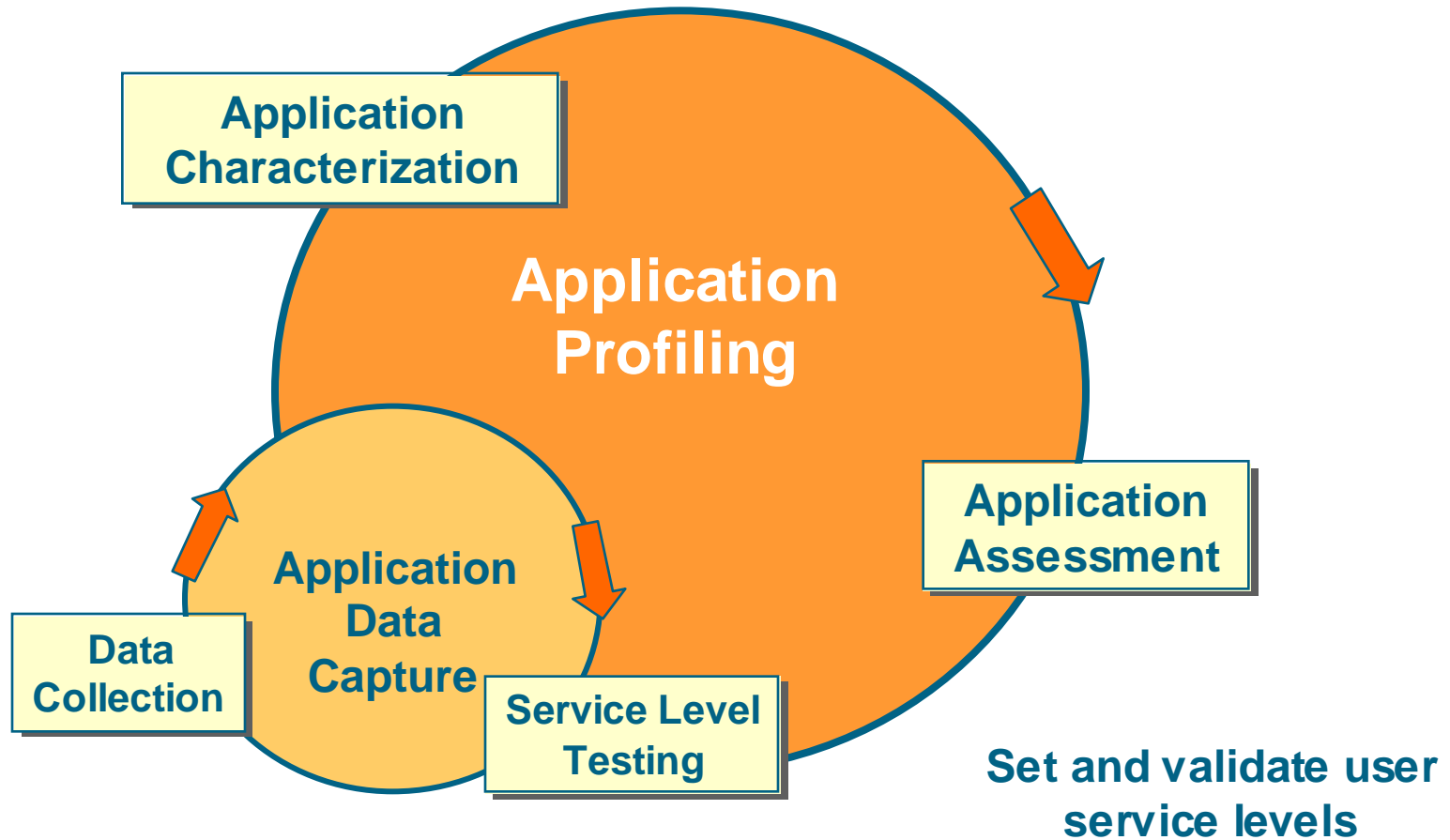

# Application Architecture

- Two-tier vs. three-tier vs. n-tier
- What traffic flows to collect

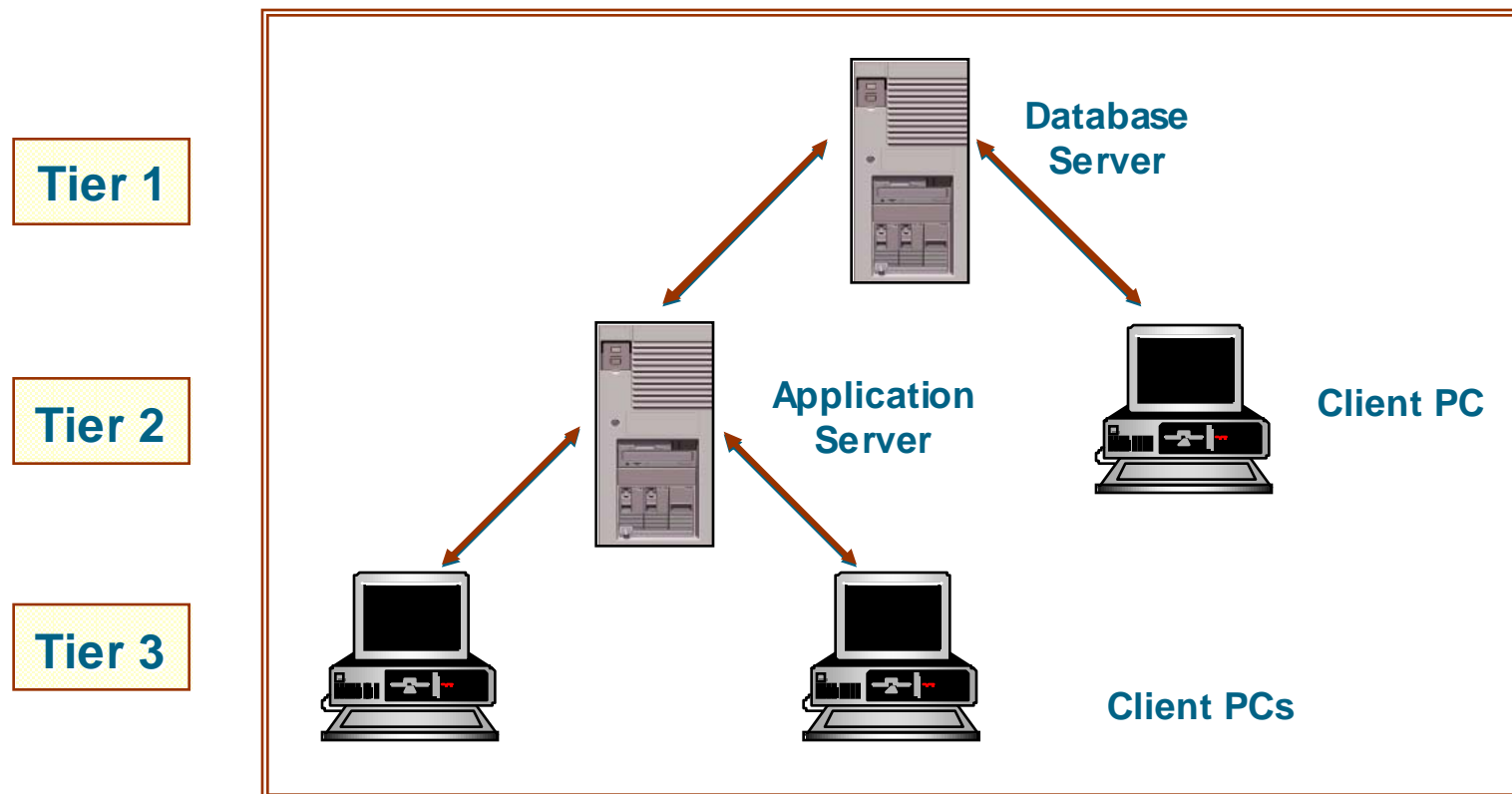

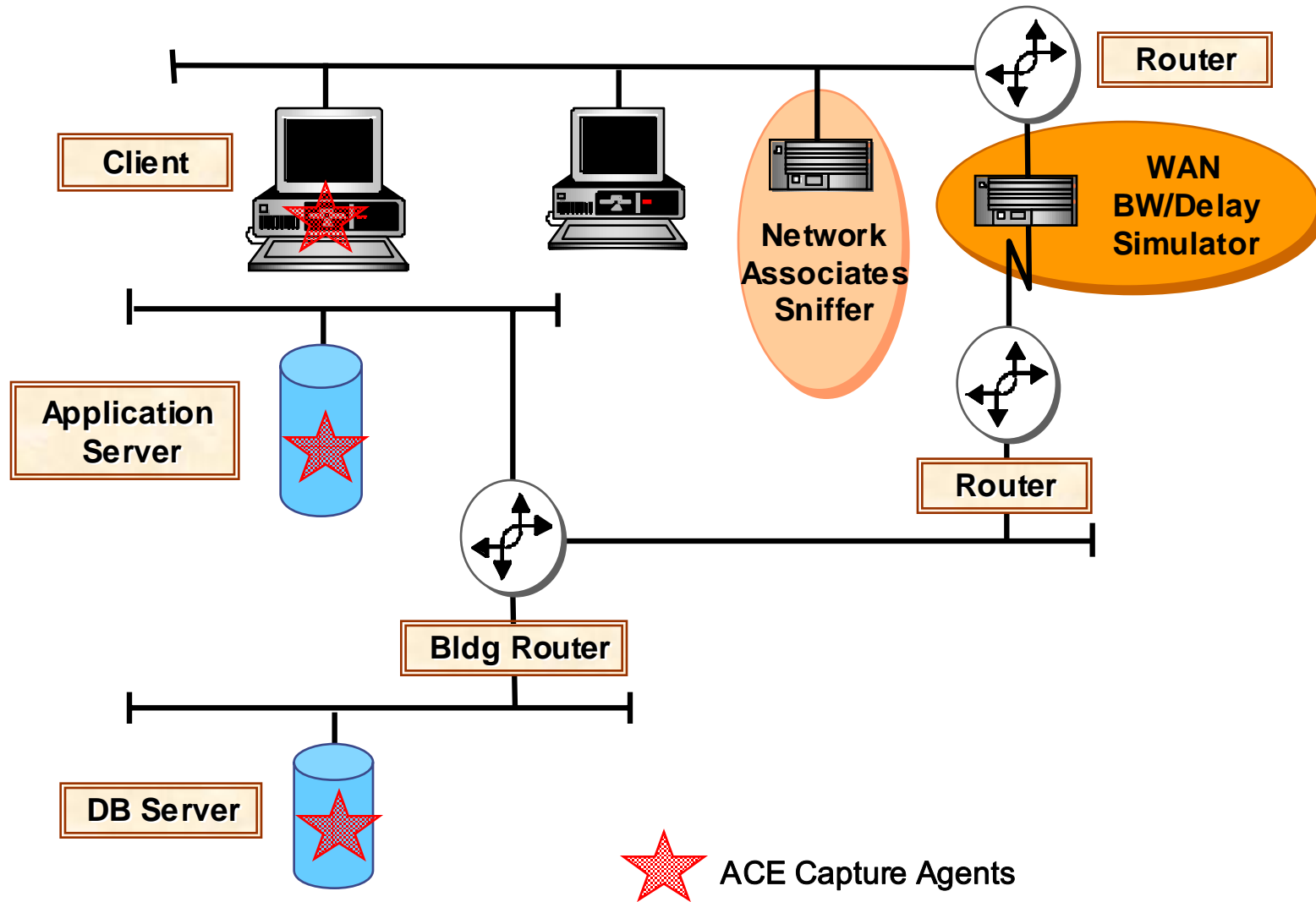

# Application Quality of Service

- QoS is a function of
  - Client/server architecture
  - Network performance

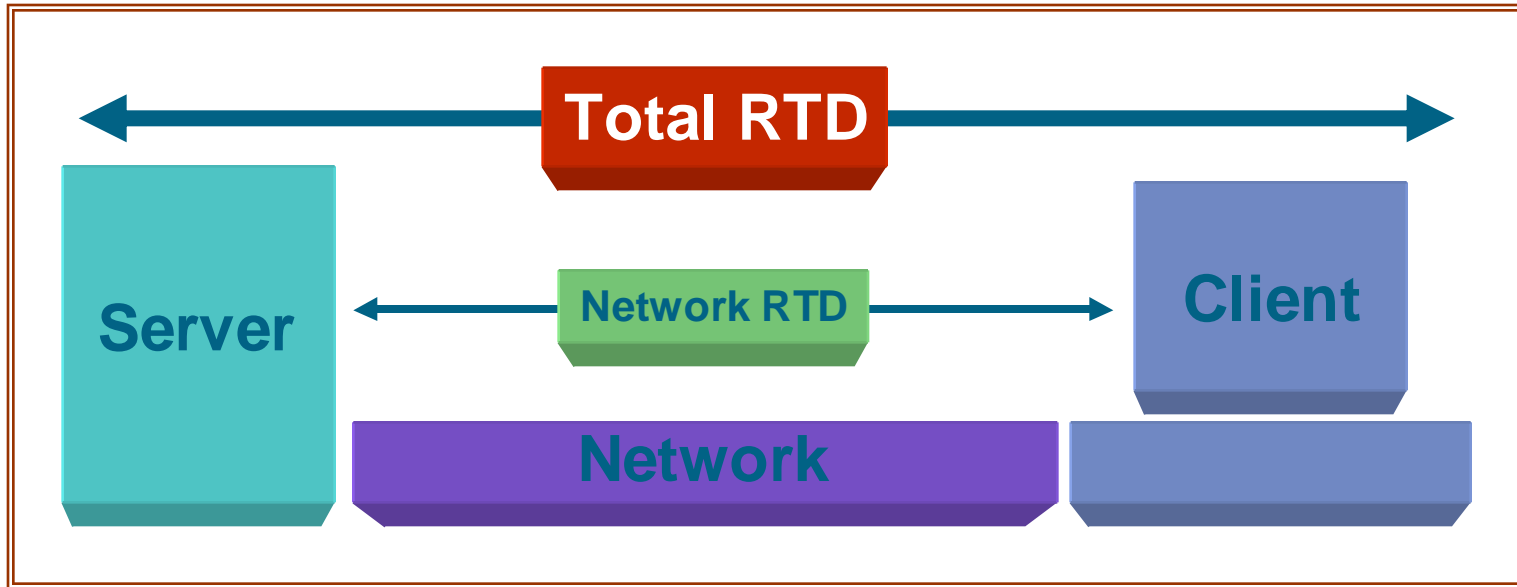

# Capacity Planning

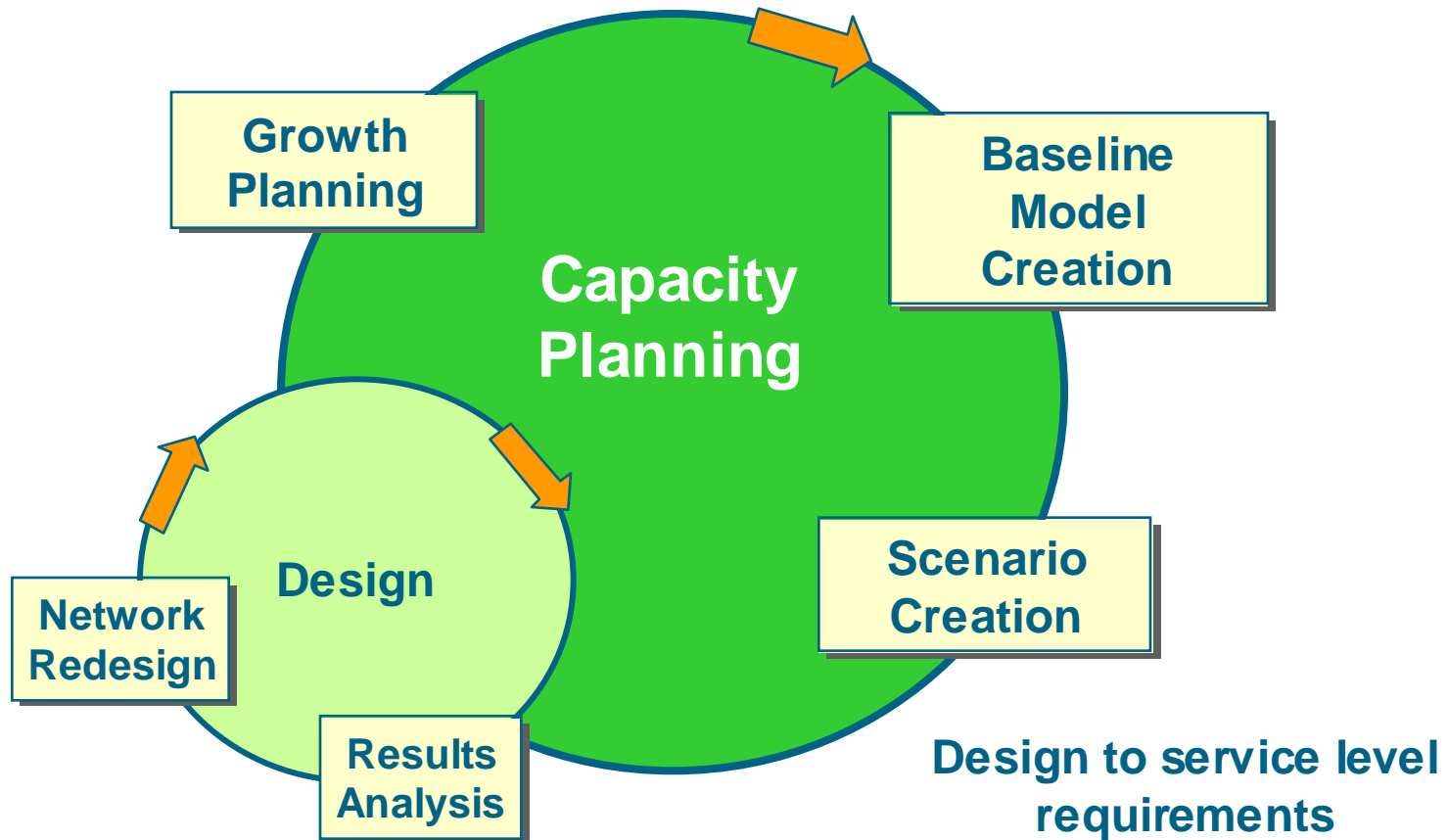

# Calculating Response Time

- Fwd Delay =  $D1 + D2 + D3 + D4 + D5 + D6 + D7$

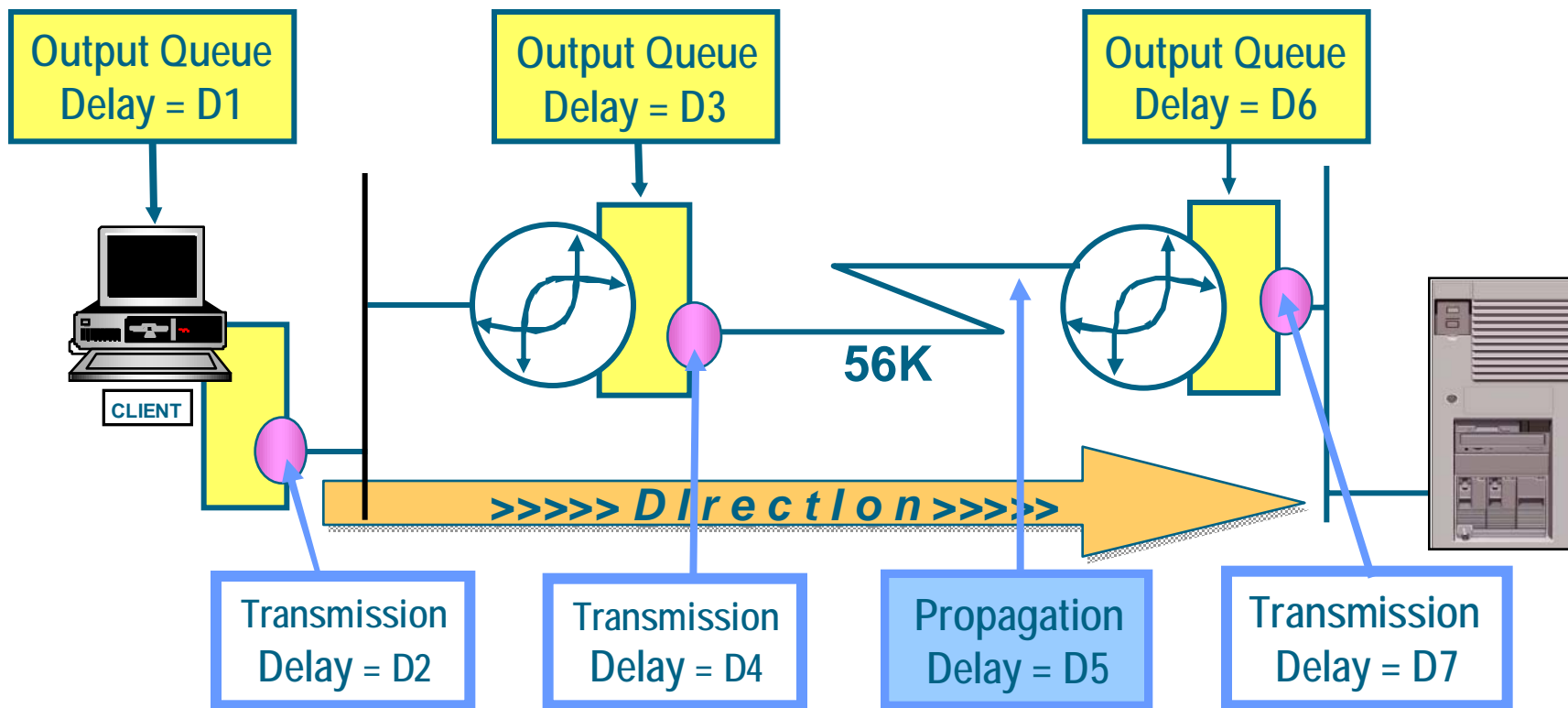

# OPNET's Virtual Network Environment

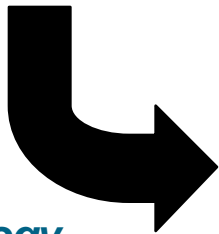

*Topology,  
Traffic,  
Configurations,  
Workload Data*

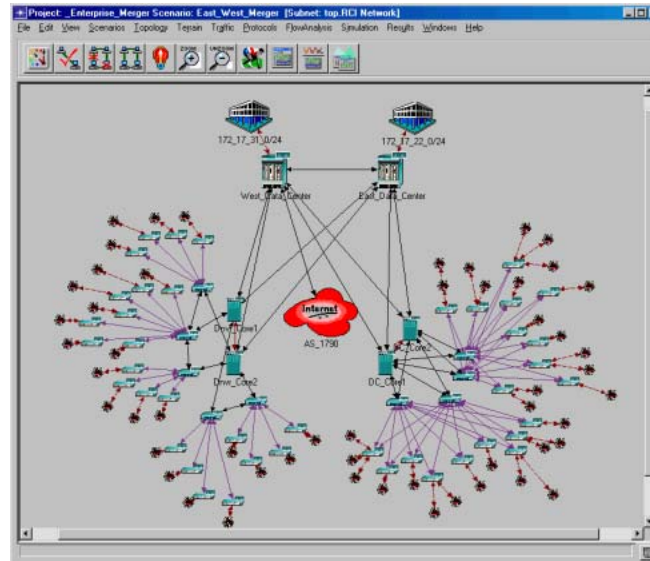

## Virtual Network Environment

*A model of your infrastructure, including its routers, switches, systems, protocols, traffic, and applications*

Application Performance  
Troubleshooting

Application  
Networkability  
Assessment

Application Impact  
Assessment

Automatic Network  
Diagnostics

Device Configuration  
Change Certification

Network Growth Planning

Failure Impact  
Assessment

Server Capacity Planning  
and Consolidation